

# ST. COLUMBUS SCHOOL

Dayal Bagh, Surajkund, Faridabad-121009 (Haryana)

## CLASS – I PRACTICE ASSIGNMENT

Dear Parent,

Kindly note down the Practice Assignment Instructions:

- ✓ Parental guidance may be sought wherever necessary.
- ✓ Ensure that all written work is neatly completed in the child's own handwriting.
- ✓ Regular practice of reading and writing is highly recommended during the holidays.

With the onset of winter, children are more susceptible to seasonal ailments such as colds and coughs. It is imperative to ensure their well-being by taking adequate precautions, especially when venturing outdoors.

Note:

Kindly ensure that the Practice Sheets are pasted in the respective notebooks and submitted on the first working day after the holidays.

# ST. COLUMBUS SCHOOL

Dayal Bagh, Surajkund, Faridabad-121009 (Haryana)

## PRACTICE WORKSHEET (2024-25)

### SUBJECT - ENGLISH

Date: \_\_\_\_\_

CLASS - I

Name: \_\_\_\_\_

Sec.: \_\_\_\_\_

Roll No.: \_\_\_\_\_

### The New Bicycle

Emma has a new bicycle. It is bright pink and shiny. It was a gift from her uncle. He hid it behind a bush to surprise her.

When Emma looked behind the bush and saw the bicycle, she jumped for joy. It was just what she wanted. She gave her uncle a big hug. She loves her new bicycle, and she loves her uncle.



**Q1. Read the above passage and answer the following questions.**

a) What is the colour of Emma's bicycle? \_\_\_\_\_

b) Who gifted Emma the bicycle? \_\_\_\_\_

c) Where was the bicycle hidden? \_\_\_\_\_

**Q2. Write the opposite word for the following.**

a) include - \_\_\_\_\_

c) naughty - \_\_\_\_\_

b) foolish - \_\_\_\_\_

d) cruel - \_\_\_\_\_

**Q3. Write the rhyming words for the following.**

a) hill- \_\_\_\_\_

b) well- \_\_\_\_\_

c) goat- \_\_\_\_\_

**Let's open the world of imagination!**

- ❖ **Learn the poem 'Books' and recite it with proper expression and understanding.**
- ❖ **Read Lesson 3 and 4 from your Pearls Semester 2 textbook carefully to improve your reading skills.**
- ❖ **Prepare 4-5 lines on any one of the topics: "If I Had a Super Power" or "Our Country India" for your speaking skills.**
- ❖ **Complete cursive writing pages 36 to 56 in your Cursive Strokes writing book 'FUN WITH CURSIVE WRITING' to improve your handwriting.**

# ST. COLUMBUS SCHOOL

Dayal Bagh, Surajkund, Faridabad-121009 (Haryana)

## PRACTICE WORKSHEET (2024-25)

### SUBJECT – MATHEMATICS

Date: \_\_\_\_\_

CLASS - I

Name: \_\_\_\_\_

Sec.: \_\_\_\_\_

Roll No.: \_\_\_\_\_

**Q1. Write the number names for the following.**

a) 89- \_\_\_\_\_

b) 44- \_\_\_\_\_

c) 69- \_\_\_\_\_

d) 13- \_\_\_\_\_

e) 100- \_\_\_\_\_

**Q2. Dodging tables**

a)  $9 \times 2 =$  \_\_\_\_\_

d)  $8 \times 6 =$  \_\_\_\_\_

b)  $7 \times 7 =$  \_\_\_\_\_

e)  $0 \times 5 =$  \_\_\_\_\_

c)  $10 \times 3 =$  \_\_\_\_\_

f)  $6 \times 4 =$  \_\_\_\_\_

**Q3. Subtract the following.**

a) T O

6 7

- 2 3

b) T O

3 5

- 2 2

c) T O

5 6

- 1 0

**Write with Fun!**

- ❖ **Revise and practice tables from 1 to 10 daily to memorize them thoroughly.**
- ❖ **Learn number names 1-100.**

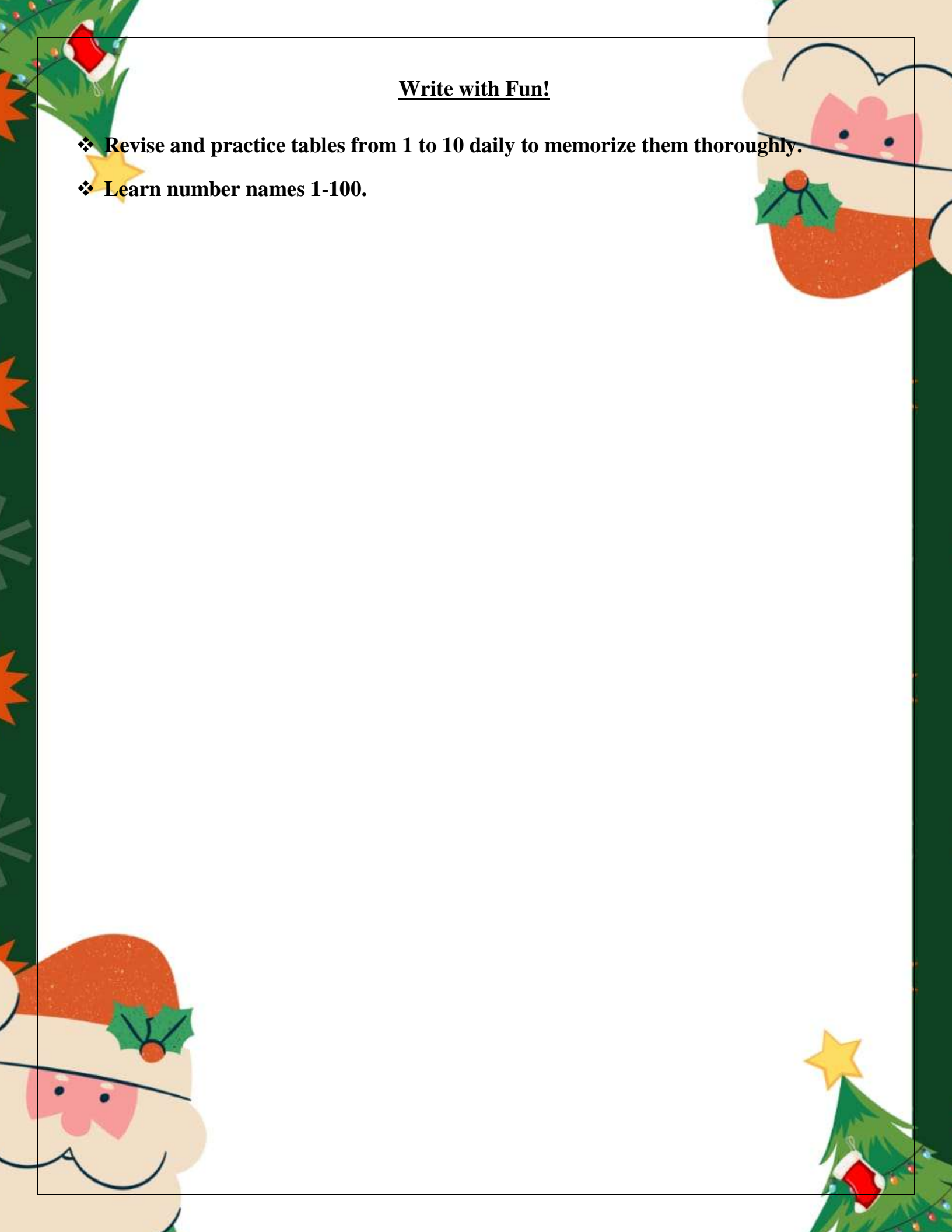

# ST. COLUMBUS SCHOOL

Dayal Bagh, Surajkund, Faridabad-121009 (Haryana)

## PRACTICE WORKSHEET (2024-25)

SUBJECT- EVS

Date: \_\_\_\_\_

CLASS - I

Name: \_\_\_\_\_

Sec.: \_\_\_\_\_

Roll No.: \_\_\_\_\_

Q1. Answer the following questions in one word.

a) Who teaches children in a school?

\_\_\_\_\_

b) Who treats us when we are sick?

\_\_\_\_\_

c) Who brings letters to our homes?

\_\_\_\_\_

d) Who grows food for us in the fields?

\_\_\_\_\_

Q2. Identify the pictures and name them.



a) \_\_\_\_\_



b) \_\_\_\_\_

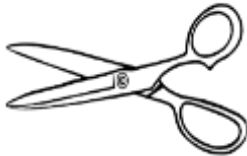

c) \_\_\_\_\_



d) \_\_\_\_\_

Q3. Circle the odd one out in each set.

a) nurse

doctor

soil

b) post office

fields

postman

c) teacher

chalk

comb

**Let's explore!**

- ❖ **Revise Ch-2 of your textbook (Pearls Semester 2) and practice its exercises.**
- ❖ **Paste 2 pictures of the following in an A4 size coloured sheet and paste it in your notebook: -**

**a) Farm animals**

**b) Pet animals**

**c) Wild animals**

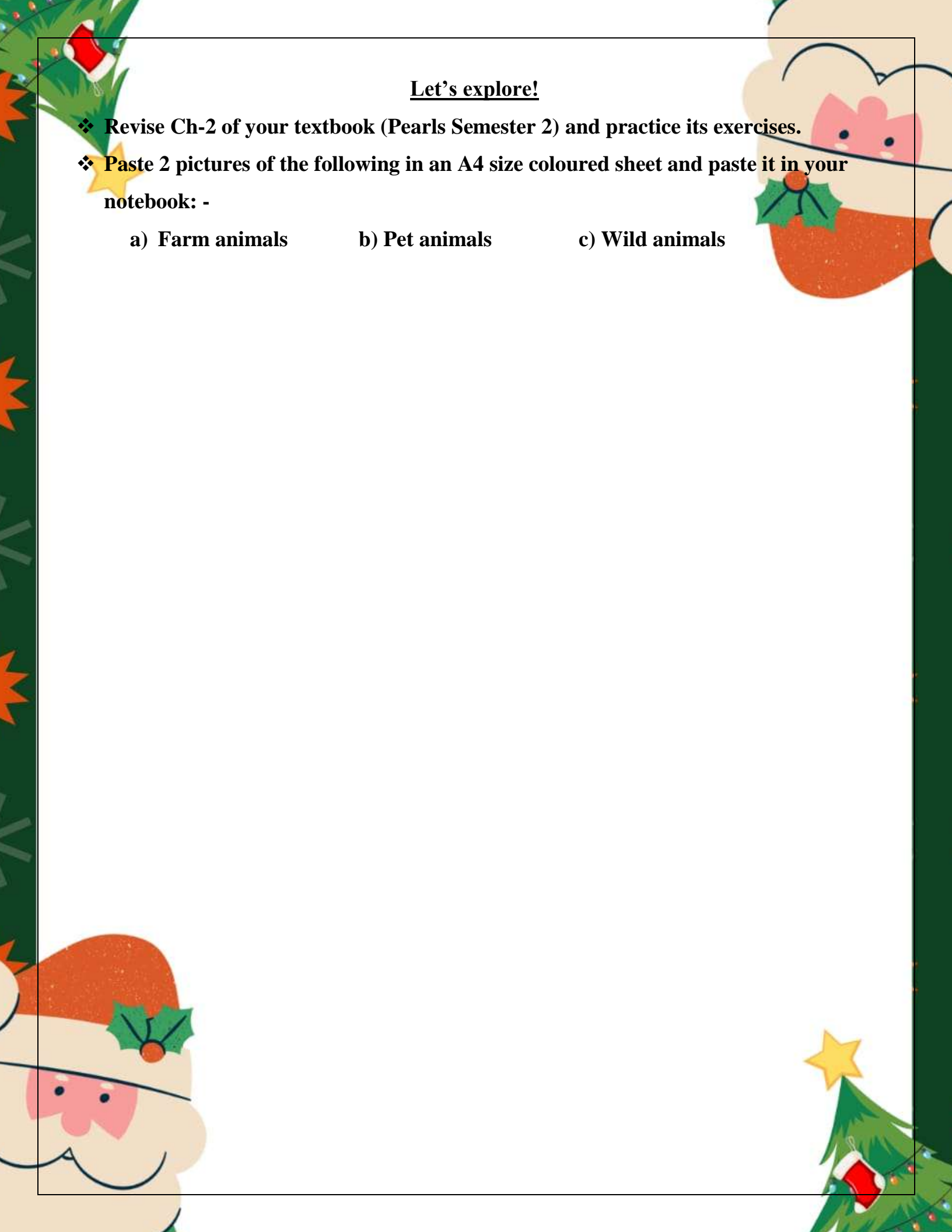

# ST. COLUMBUS SCHOOL

Dayal Bagh, Surajkund, Faridabad-121009 (Haryana)

## PRACTICE WORKSHEET (2024-25)

### SUBJECT - HINDI

Date: \_\_\_\_\_



CLASS - I

Name: \_\_\_\_\_

Sec.: \_\_\_\_\_

Roll No.: \_\_\_\_\_

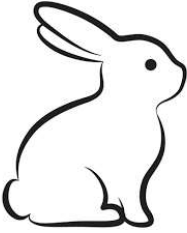
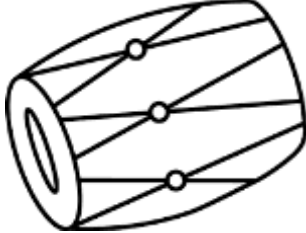
प्रश्न- 1 चित्रों को देखकर उनके नाम लिखिए।

		
क) _____	ख) _____	ग) _____

प्रश्न-2 वाक्य बनाइए।

टोपी- \_\_\_\_\_

प्रश्न-3 दो पक्षियों के नाम लिखिए।

क) \_\_\_\_\_



ख) \_\_\_\_\_

प्रश्न-4 शब्द बनाइए।

क) क + ो + ट - \_\_\_\_\_

ख) ह + ो + ठ - \_\_\_\_\_



- 
- ओ व औ मात्रा के तीन पक्षियों के नाम लिखिए व उनमें से किसी एक विषय में पाँच-पाँच वाक्य ए4 शीट में लिखिए।
  - हिंदी पाठ्यपुस्तक वसुंधरा में से पाठ सुनो कहानी (ओ मात्रा) तथा मौसा-मौसी भी मुसकाए (औ मात्रा) का पठन अभ्यास कीजिए।
  - पाठ्यपुस्तक वसुंधरा में से बाल गीत (पृष्ठ सं – 60) कविता याद कीजिए।
  - नए शब्द के अभ्यास पत्र में से 1 से 30 तक (ओ व औ मात्रा) के नए शब्द याद कीजिए।
  - लेखन पाती सुलेख पुस्तिका में पृष्ठ सं. 40 से 56 तक सुंदर व स्पष्ट लेख कीजिए।
- 

# ST. COLUMBUS SCHOOL

Dayal Bagh, Surajkund, Faridabad-121009 (Haryana)

PRACTICE WORKSHEET (2024-25)

SUBJECT - ART

Date: \_\_\_\_\_

CLASS - I

Name: \_\_\_\_\_

Sec.: \_\_\_\_\_

Roll No.: \_\_\_\_\_

Q1. Colour the given picture.

